



Room panel

ecoSTER 200

HARDWARE VERSION 2

FOR ECOMAX CONTROLLERS



OPERATION AND MAINTENANCE MANUAL

ISSUE_EN: 1.1

APPLICABLE TO SOFTWARE: v10.XX.XXX

1.	SAFETY	4		
2.	PURPOSE	4		
3.	INFORMATION ABOUT DOCUMENTATION	4		
4.	STORAGE OF DOCUMENTATION.....	4		
5.	APPLIED SYMBOLS	4		
6.	WEEE 2002/96/EC DIRECTIVE	4		
7.	OPERATING MANUAL	5		
7.1	SWITCHING THE PANEL ON	5		
7.2	SWITCHING THE PANEL OFF	5		
7.3	PANEL BLOCKADE.....	5		
7.4	OPERATION.	5		
7.5	MAIN SCREEN	5		
7.6	OPERATION MODES.....	6		
7.6.1	Operation mode with a schedule	6		
7.6.2	Economic mode	6		
7.6.3	Comfort mode.....	6		
7.6.4	"Output" Mode	6		
7.6.5	Airing mode.....	6		
7.6.6	Party mode.....	6		
7.6.7	Holiday mode.....	7		
7.6.8	Anti-freeze mode	7		
7.7	PROFILES.....	7		
7.8	SCHEDULE	7		
7.8.1	Programming schedules.....	7		
7.9	PRESET ROOM TEMPERATURE.....	8		
7.10	ecoMAX BOILER REGULATOR MENU	8		
7.11	SETTINGS	8		
7.11.1	Weather sensor	8		
7.11.2	Thermostat settings	9		
7.11.3	Hysteresis.....	9		
7.11.4	Temperature correction	9		
7.11.5	Language change	9		
7.11.6	Sound alarm.....	9		
7.11.7	Clock settings	9		
7.11.8	Brightness screen setting.....	9		
7.11.9	Information	9		
8.	INSTRUCTIONS FOR PANEL ASSEMBLY	9		
8.1	TECHNICAL DATA	9		
8.2	STORAGE AND TRANSPORTATION CONDITIONS	10		
8.3	ENVIRONMENTAL CONDITIONS	10		
8.4	ASSEMBLY REQUIREMENTS.....	10		
8.5	INSTRUCTIONS FOR ASSEMBLY	10		
8.6	ELECTRICAL CONNECTION TO THE MODULE CONTROLLERS ecoMAX.....	10		
8.6.1	Connection to ecoMAXX800 R2,T2 and ecoMAX800 P1,P2,D1,D2.....	11		
8.6.2	Connection to ecoMAXX800 R3,T3 and ecoMAX800 P3,D3	12		
8.6.3	Connection to ecoMAX850 P1.....	12		
8.6.4	Connection to ecoMAX850 P2,R2,D2	13		
8.6.5	Connection to ecoMAX860 P1,P2,D1,D2...	13		
8.7	ASSEMBLING SENSORS OF THERMOSTAT 2 AND 3.....	14		

1. Safety



Incorrect electrical connection of the room panel with ecoMAX regulator can cause damage both to the ecoSTER200 room panel and ecoMAX regulator. Therefore, installation has to be done by a qualified installer.

Additional protective measures should be taken in order to prevent results of malfunction of the regulator or of errors in its software which could result in a loss of property or other dangerous consequences, i.e. freezing of water in hydraulic system.

2. Purpose

EcoSTER200 room panel is a modern electronic device mainly used as a programmable room thermostat. The regulator provides very simple and effective way to control indoor temperature. Temperature sensor included in the regulator enables reading and programming temperature with the accuracy of 0,1°C. Regulator can be programmed in a 7-day cycle with the accuracy of 0,5 hour. Therefore, there is a possibility of 48 temperature changes per day. User can preset different time zones for each day of the week.

After connecting two additional temperature sensors, the ecoSTER200 room panel provides temperature control in three independent rooms.

The ecoSTER200 room panel also has a function of additional panel for boiler regulator control.

It can be used in household and similar facilities, as well as in slightly industrialized facilities.

3. Information about documentation

The ecoSTER200 room panel manual is a supplement for the corresponding ecoMAX regulator. In particular, except for this manual, the regulator manual should also be observed. We are not responsible for any damages caused by failure to observe these instructions.

4. Storage of documentation

This assembly and operation manual, as well as any other applicable documentation, should be stored diligently, so that it was available at any time. In the case of moving or selling the device, the attached documentation should be forwarded to the new user/owner.

5. Applied symbols

In this manual the following graphic symbols are used:



- useful information and tips,



- important information; failure to observe these can cause damage of property, threat for human and household animal health and life.

Caution: the symbols indicate important information, in order to make the manual more lucid. Yet, this does not exempt the user and installer from the obligation to comply with requirements which are not marked with graphic symbols!

6. WEEE 2002/96/EC Directive Act on electrical and electronic equipment



- Recycle the product and the packaging at the end of the operational use period in an appropriate recycling plant,
- Do not dispose of the product together with normal waste,
- Do not burn the product.

7. Operating manual

7.1 Switching the panel on

To switch the panel on, press TOUCH&PLAY button.

7.2 Switching the panel off

To switch the panel off, push the button in a main window of one of the thermostats, hold it for at least 3s and select "Switch off" (from the list).

 Switching the ecoSTER200 room panel off does not result in switching the ecoMAX boiler off.

7.3 Panel blockade

In order to lock the panel, push the button in a main window of one of the thermostats, hold it for at least 3s and select "Lock" from the list. When the panel is locked, a key symbol is displayed in a main window next to a clock.

In order to unlock the panel, hold the button for at least 4 seconds.

7.4 Operation.

The panel is equipped with TOUCH&PLAY button which facilitates the operation. This button is operated by turning and pushing.

Push the button shortly to edit a particular parameter. In order to exit the parameter edition mode or particular menu, hold the button for at least 2s. Modify the edited value by turning the button right or left.



The ecoSTER200 panel operation is easy and intuitive. When the panel displays main window, turn the button right or left in order to change displayed main window: 1, thermostat 2. thermostat 3, boiler. If temperature sensors of thermostats 2 and 3 are not connected, the mains screens of thermostats 2 and 3 are not available.

Push the button shortly to display menu. Type of displayed menu will be according to a currently displayed main screen. For example, if you select the room thermostat 1 on the main screen, entering to menu will result in displaying settings for the first thermostat and common settings. When the main window for boiler settings is displayed, entering to menu will result in displaying boiler settings, etc.







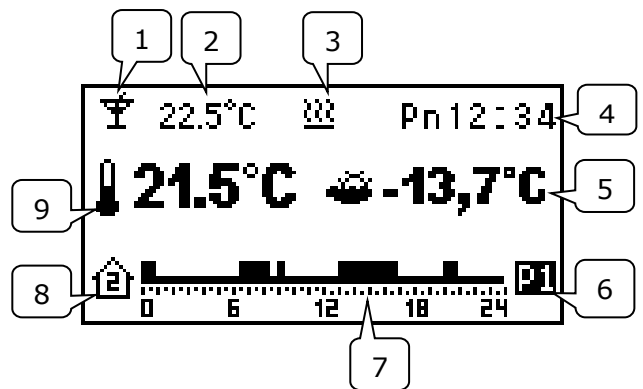



For example, in order to change settings of thermostat 3, display the main screen of thermostat 3 by turning the button and push the button shortly in order to enter the settings menu of this thermostat.

7.5 Main screen



1. Current operation mode of room thermostat:

-  - Schedule
-  - Economic
-  - Comfort
-  - Output
-  - Airing
-  - Party
-  - Holiday
-  - Anti-freeze
-  - ON

2. Current preset room temperature.
3. Indication of active thermostat (heating).
4. Clock.
5. Current external temperature (only available when a weather sensor is connected to the boiler regulator).

6. Currently selected profile.
7. Graphic presentation of programmed time zones (schedule).
8. Number of thermostat for which this main screen is displayed.
9. Current, measured room temperature.

7.6 Operation modes

7.6.1 Operation mode with a schedule

In this mode, the regulator presets the temperature in rooms according to a time schedule. In the main window, in a place for displaying operation mode, a clock icon  is displayed. To set this mode, select:

MENU → Operation mode → Schedule

Programming a schedule is described in 7.8.1

7.6.2 Economic mode

In this mode, the regulator works with constant economic preset temperature, set in the following parameter:

MENU → Temperature Settings → Night temperature

In the main window, in a place for displaying operation mode, a quarter moon  icon is displayed. In order to activate this mode, select:

MENU → Operation Mode → Economic

7.6.3 Comfort mode

In this mode, the regulator works with constant comfort preset temperature set in the following parameter:

MENU → Temperature Settings → Day temperature

In the main window, in a place for displaying operation mode, a sun  icon is displayed. In order to activate this mode, select:

MENU → Operation mode → Comfort

7.6.4 "Output" Mode

This mode enables to replace the existing temperature setting for a period of 1 to 60 hours with an economic temperature set in the following parameter:

MENU → Temperature Settings → Night temperature. In order to activate this mode, enter the MENU and select:

Operation mode → Output

Screen for editing the duration of this mode will be displayed. After setting the required duration and confirming by pushing the button, the "Output" operation mode is activated; in this mode, the economic temperature is set to a preset duration.

Note: Time will be counted by full hours. It means that the first hour will not be a full hour - it will be a number of minutes left to a current full hour.

For example, if the manual mode is set to 17:45 for a duration of 4 hours, a real duration of the party mode will be 3h 15 min. When a preset time elapses, the regulator switches to a previous mode. In the main window, in a place for displaying operation mode, an open door  icon is displayed.

7.6.5 Airing mode

Selecting the airing mode in thermostat 1 will close mixers and switch off central heating pump in the boiler regulator for 1 to 60 minutes. In order to activate this mode, enter the MENU and select:

Operation mode → Airing

Screen for editing the duration of this mode will be displayed. After setting the required duration and confirming by pushing the button, the Airing operation mode is activated.

Note: Time will be counted by full minutes. It means that the first minute will not be a full minute - it will be a number of seconds left to a current full minute.

When a preset time elapses, the regulator switches to a previous mode. In the main window, in a place for displaying operation

mode, an open window  icon is displayed. During this mode, a thermostat contact remains opened.

7.6.6 Party mode

Party mode enables to replace the existing temperature setting for a period of 1 to 48 hours with any temperature. In order to activate this mode, enter the MENU and select:

Operation mode → Party

The preset room temperature edition window will be displayed. Set the required temperature by turning the button right or left. Push the button to confirm and save the

set temperature value; the mode duration time edition window will be displayed. After setting the required duration and confirming by pushing the button, the Party operation mode is activated; in this mode, the temperature is set to a preset duration.

Note: Time will be counted by full hours. It means that the first hour will not be a full hour - it will be a number of minutes left to a current full hour.

For example, if the manual mode is set to 17:45 for a duration of 4 hours, a real duration of the party mode will be 3h 15 min. When a preset time elapses, the regulator switches to a previous mode. In the main window, in a place for displaying operation mode, a glass ☼ icon is displayed.

7.6.7 Holiday mode

Holiday mode enables to replace the existing temperature setting for a period of 1 to 99 days with a constant temperature. This function is particularly useful in case of holiday departure:

In order to activate this mode, enter the MENU and select:

Operation Mode → Holiday

The preset room temperature edition window will be displayed. Set the required temperature by turning the button right or left. Push the button to confirm and save the set temperature value. Next, the Holiday mode duration time edition window will be displayed. After setting the required duration and confirming by pushing the button, the Holiday operation mode is activated; in this mode, the temperature is set to a preset duration.

Note: Time will be counted by full days. It means that the first day will not be a full day - it will be a number of hours left to a current full day.

For example, if the manual mode is set to 17:45 for a duration of 14 days, a real duration of the Holiday mode will be 13 days 6 hours and 15 minutes.

When a preset time elapses, the regulator switches to a previous mode. In the main window, in a place for displaying operation mode, a suitcase  icon is displayed.

7.6.8 Anti-freeze mode

In this mode, the regulator works with constant preset temperature, set in the following parameter:

MENU → Temperature Settings → Anti-freeze temperature

In the main window, in a place for displaying operation mode, a snowflake  icon is displayed.

Selecting the anti-freeze mode in thermostat 1 will set the hot utility water temperature in the ecoMAX boiler regulator to 8°C.

7.7 Profiles

The ecoSTER200 room panel enables programming four profiles of schedules. The following set of parameters is recorded for each profile:

- schedule for all weekdays
- night temperature (economic)
- day temperature (comfort)
- anti-freeze temperature
- hysteresis

Profile changing mechanism is very useful if there is a need of cyclical changes in schedule; for example when user works on various shifts. Then, by selecting a profile, you can rapidly switch between several programmed schedules without a necessity of editing them.

7.8 Schedule

Regulator can be programmed in 7-day cycle with an accuracy of 0,5 hour. Therefore, there is a possibility of 48 temperature changes per day.

Regulator enables programming two levels of temperature: day (comfort) and night (economic). Regulator enables programming various time zones individually for each weekday.

7.8.1 Programming schedules

In order to program a schedule for a particular thermostat, display the main screen of this thermostat (pt. 7.4) and select: **MENU → Schedule**

Then, choose a weekday for which you want to establish or modify a schedule. After selecting a weekday, a window for editing a schedule is displayed.

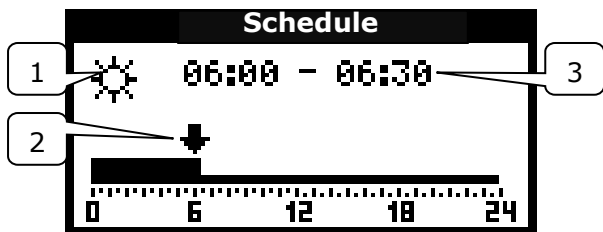

1. Preset temperature: comfort or economic
2. Arrow indicating currently edited time interval
3. Currently edited time interval.

In order to set required time interval, you should:

- by turning the button, set the arrow on a time zone starting hour
- by pushing the button, set the comfort or economic temperature (it is indicated by displaying a sun or moon symbol in the upper left corner of edition window)
- turn the button and set the arrow on a time zone ending hour
- finish the edition of a particular zone by pushing the button
- if needed, repeat the steps above for other time interval - in order to exit a schedule window, push and hold the button for at least 2 seconds

After exiting the schedule editing mode, a window is displayed which enables you to assign currently edited schedule to any day of the week.

Apply for days			
Su	<input checked="" type="checkbox"/>	Th	<input type="checkbox"/>
Mo	<input type="checkbox"/>	Fr	<input type="checkbox"/>
Tu	<input type="checkbox"/>	Sa	<input type="checkbox"/>
We	<input type="checkbox"/>		
Save and exit			

Select weekdays for which the currently edited schedule is to be assigned and then, select "Save and exit".

7.9 Preset room temperature

Preset night (economic) temperature is set in:

MENU → Temperature settings → Night temperature

Preset day (comfort) temperature is set in:

MENU → Temperature settings → Day temperature

Preset anti-freeze temperature is set in:

MENU → Temperature settings → Anti-freeze temperature

7.10 ecoMAX boiler regulator menu

In order to display the ecoMAX (2) boiler regulator main screen, turn the button right when the thermostat main screen is displayed. Push the button shortly to display the boiler regulator menu. This menu is similar as in ecoMAX boiler regulator and therefore, the instructions of boiler regulator have to be followed.

The ecoSTER200 room panel displays alarms reported by the ecoMAX boiler regulator. In case when generation of sound alarm is activated (pt. 7.11.6), pushing the button will result in deactivation of acoustic signal. However, the alarm will not be cancelled. For safety reasons it could be done only by the boiler regulator.

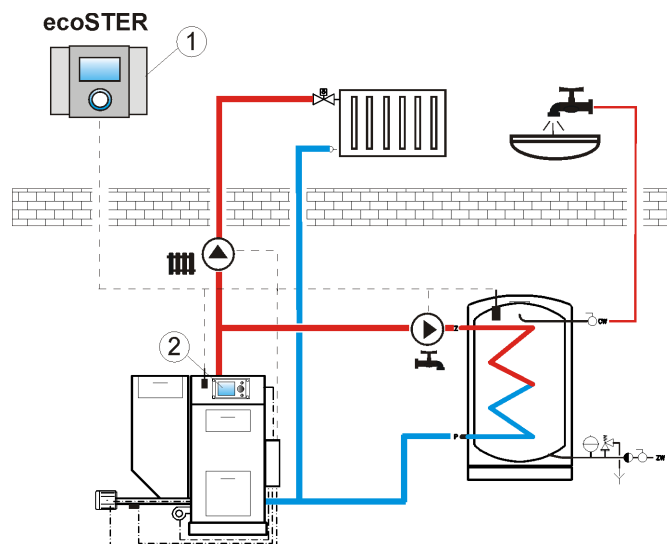

Diagram of cooperation of ecoSTER200 with ecoMAX, where 1 - ecoSTER200, 2 - ecoMAX boiler regulator.

7.11 Settings

In order to enter the setting menu, select:

MENU → Settings

7.11.1 Weather sensor

This parameter is used only in case when there is an external temperature (weather) sensor connected to the boiler regulator. Set this parameter to display measured external temperature in the main window of all thermostats.

7.11.2 Thermostat settings

This parameter enables or disables operation of particular ecoSTER200 thermostats.



Enabling or disabling thermostat 2 or 3 is possible only in case when there are additional external temperature sensors connected to the ecoSTER200 room panel.



When thermostat 2 or 3 is disabled, its main screen is not displayed.

7.11.3 Hysteresis.

This parameter defines hysteresis of room temperature. It decides of room temperature at which the room thermostat will inform the boiler regulator to heat. The boiler regulator will start heating when the room temperature drops under the *current preset temperature minus hysteresis*. It will finish heating when the current preset room temperature is reached.

7.11.4 Temperature correction

This parameter enables to make corrections of measured thermostat temperature within a range of -3.0°C to $+3.0^{\circ}\text{C}$.



Warning! The changes are not visible immediately. Wait 5 minutes to adjustment was taken into account.

7.11.5 Language change

In order to change menu language, select: **MENU → Settings → Language** and select required language from the list.

7.11.6 Sound alarm

This parameter decided whether during the alarm there will be a sound signal generated in the ecoSTER200 panel.

7.11.7 Clock settings

In order to set time and date, select:

MENU → Settings → Clock

According to set date, the device will automatically set an appropriate weekday. The ecoSTER200 panel is equipped with a system clock which is independent of the

boiler regulator clock, and therefore both clocks have to be set on the same hour.



Programmed schedule works according to the scoSTER200 panel clock.

7.11.8 Brightness screen setting

The panel has the ability to set three separate levels of screen brightness separately for day, night and when editing parameters. To adjust the brightness for the selected level, go to the **MENU → Settings → Brightness**, and then set [%] intensity.



The panel based on the internal system clock settings independently activates the programmed level of brightness in daylight hours and night.

7.11.9 Information

In this window you can obtain information concerning software version of the ecoSTER200 panel and connected ecoMAX boiler regulator.

8. Instructions for panel assembly

8.1 Technical data

Power source	+5V..12VCC
Current consumed by the device	I = 0.1 A
Protection level of the regulator	IP20
Ambient temperature	0...50 °C
Storage temperature	0...65 °C
Temperature measurement range	0...50 °C
Temperature regulation range	5...35 °C
Hysteresis	0.2...5 °C
Relative humidity	5– 85% without condensation
Terminals	Elastic clamps 0.25– 2.5mm ²
Display	Graphic 128x64
External dimensions	164x90x40 mm
Complete weight	0.2 kg
Standards	PN-EN 60730-2-9 PN-EN 60730-1
Software class	A

8.2 Storage and transportation conditions

Panel cannot be directly exposed to weather conditions, i.e. rain and solar radiation. Storage and transportation temperature should be within a range of -15...65 °C.

During transportation, the panel cannot be exposed to vibrations which are higher than typical for normal transporting conditions.

8.3 Environmental conditions

The panel should be installed in a dry residential compartment.

Moreover, the regulator cannot be used in condensation conditions and be exposed to water.

8.4 Assembly requirements

In order to guarantee a maximum operation efficiency of the regulator, follow the recommendations concerning a place of device assembly:

1. The panel is purposed for on-wall assembly inside rooms.
2. The panel should be assembled on a height app. 1.5 m over the floor level.
3. Avoid places which are strongly sunlit, close to heating devices, in direct vicinity of doors and windows, where a temperature measurement could be easily interfered by external conditions.
4. Avoid places with weak air circulation.

The panel should be installed by a qualified installer.

The manufacturer does not bear any responsibility for damages caused by failure to observe this manual.

8.5 Instructions for assembly

Open the casing as shown on the figure below:

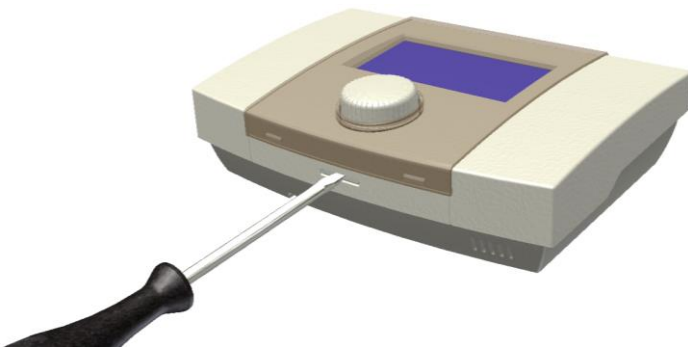

Drill holes in a wall. If a wall is made of bricks, use rawplugs. Screw in the screws.

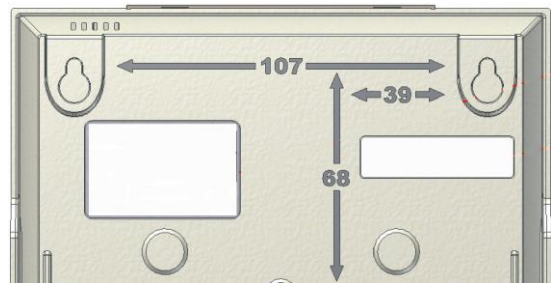

Perform electrical connections between the ecoSTER200 panel with the ecoMAX regulator. The ecoSTER200 panel is supplied by the ecoMAX regulator and does not require any supply source. Cable can be both bricked in a wall or routed on a wall surface. Do not lead connection cable together with cables of electrical network in the building. Do not lead the cable in a vicinity of devices emitting strong electromagnetic field.



Do not mix up cable poles. It can result in damaging the devices.

Closing the casing. Push the cover in a place indicated by the red arrow until you hear a clear click.

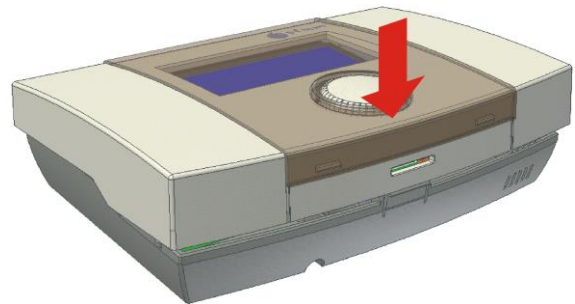

8.6 Electrical connection to the module controllers ecoMAX

ecoSTER200 room panel can be supplied with **+5V** or **+12V**, depending on the module type ecoMAX. It can be powered directly from the terminal regulator module or an external power supply from **+5V** to **+12VDC /min.200mA**, which is not included with the room panel.

Maximum length of the cable connecting the room panel with ecoMAX regulator cannot exceed **30 m**, and its cross-section area cannot be lower than **0.25 mm²**; it is recommended to use **0.5 mm²** cable.

The length of uninsulated tip of the cable should be within **8÷10mm**. Cable is inserted into a terminal by pushing a button on this terminal with a flat screwdriver, inserting the cable and releasing the button.

Below are the wiring scheme thermostats with room sensors 2 and 3 type **CT7** and the way VCC panel power module + 5V or + 12V and an optional external power supply + 5..12VDC.

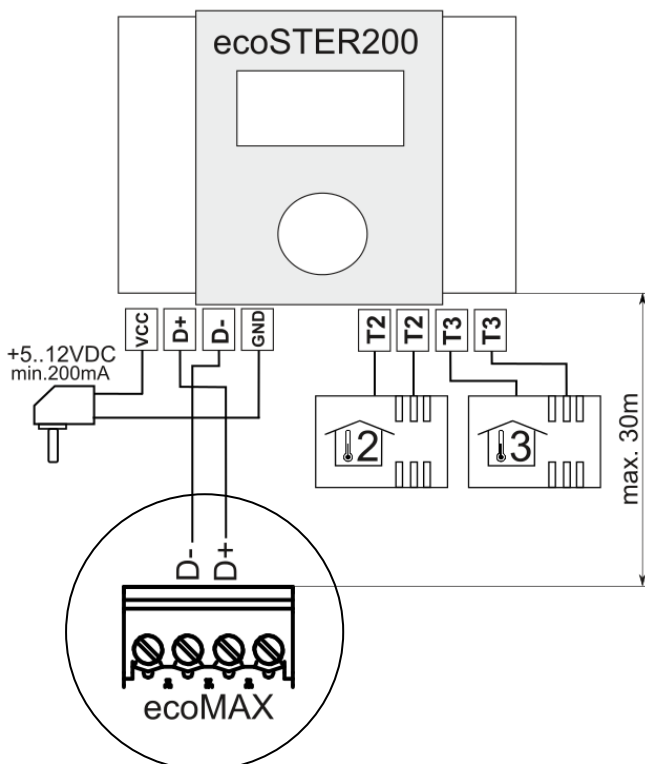
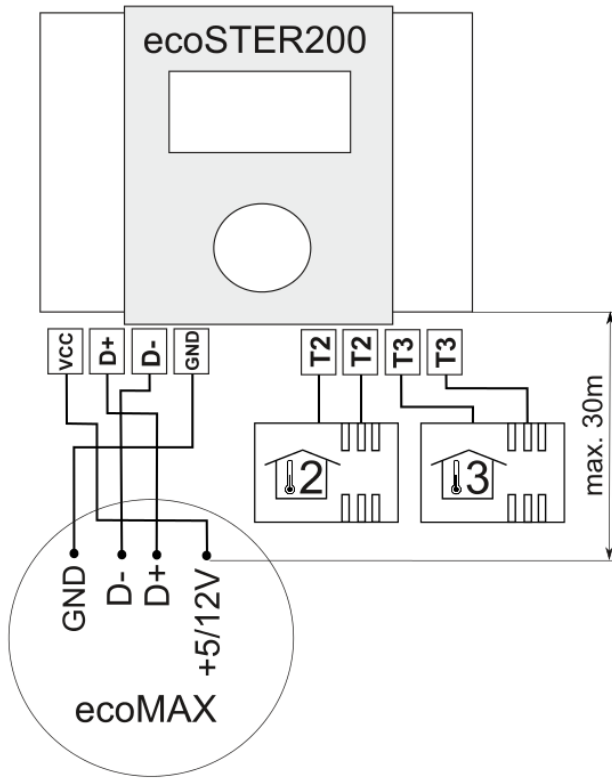

8.6.1 Connection to ecoMAXX800 R2,T2 and ecoMAX800 P1,P2,D1,D2

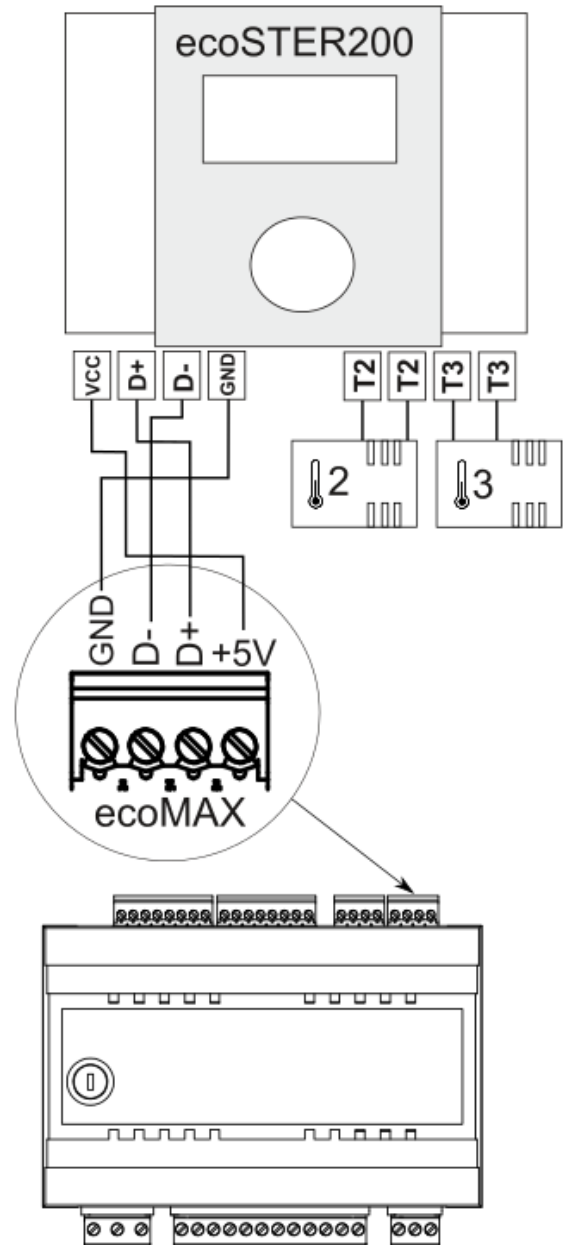

8.6.2 Connection to ecoMAX800 R3,T3 and ecoMAX800 P3,D3

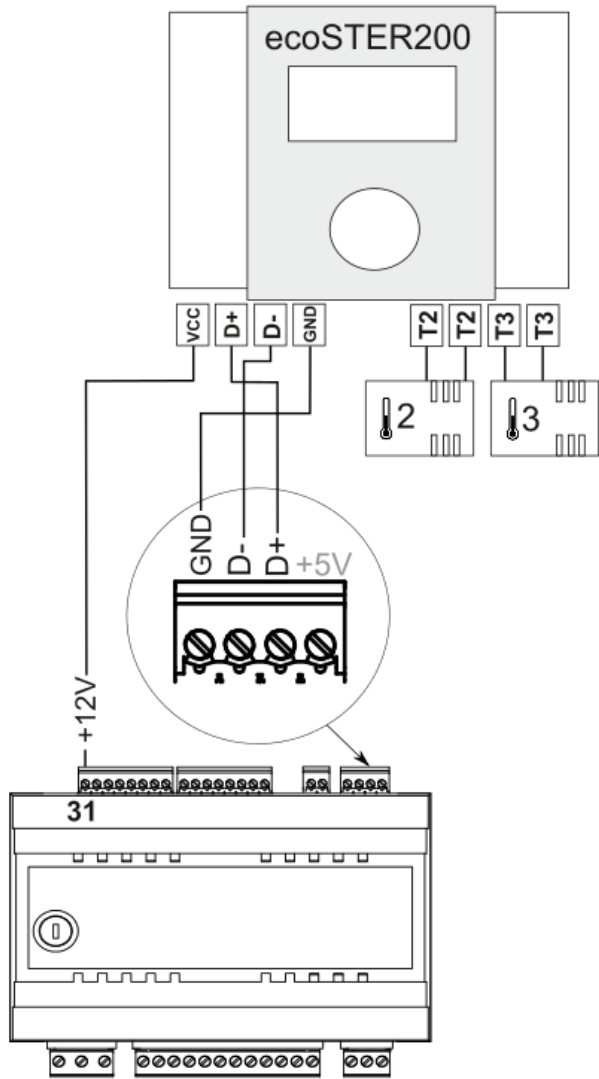

8.6.3 Connection to ecoMAX850 P1

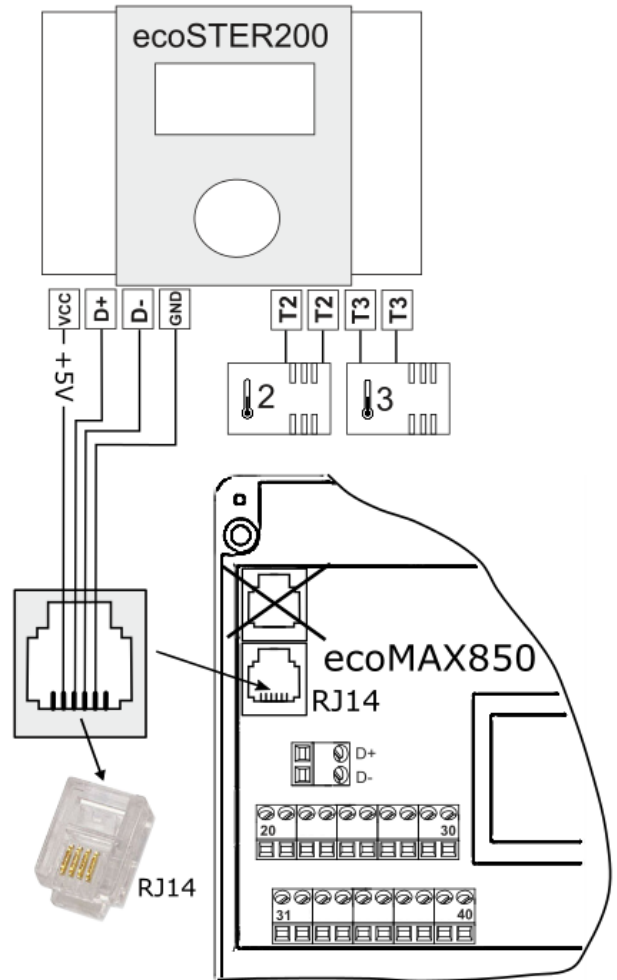

**8.6.4 Connection to ecoMAX850
P2,R2,D2**

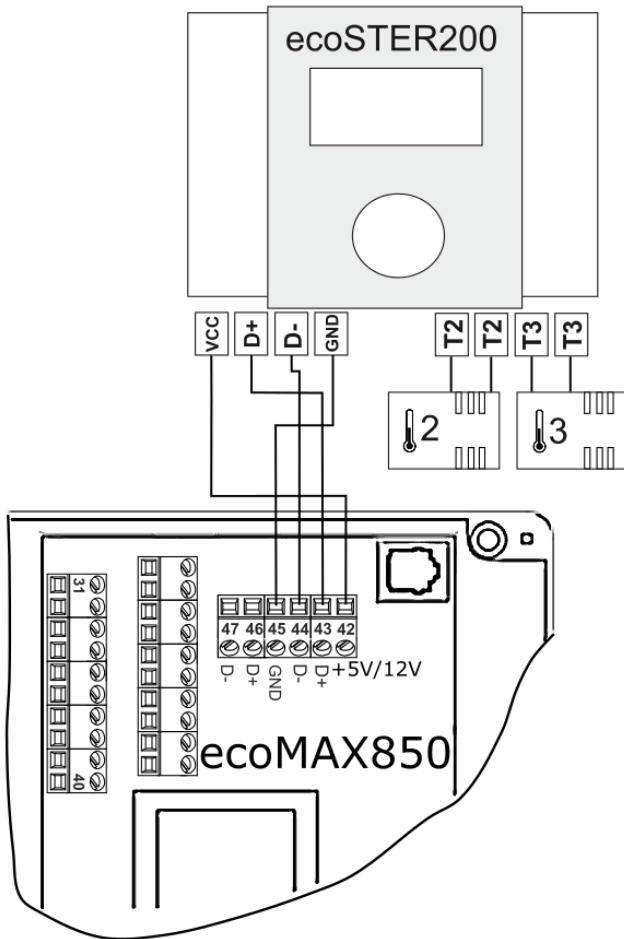

**8.6.5 Connection to ecoMAX860
P1,P2,D1,D2**

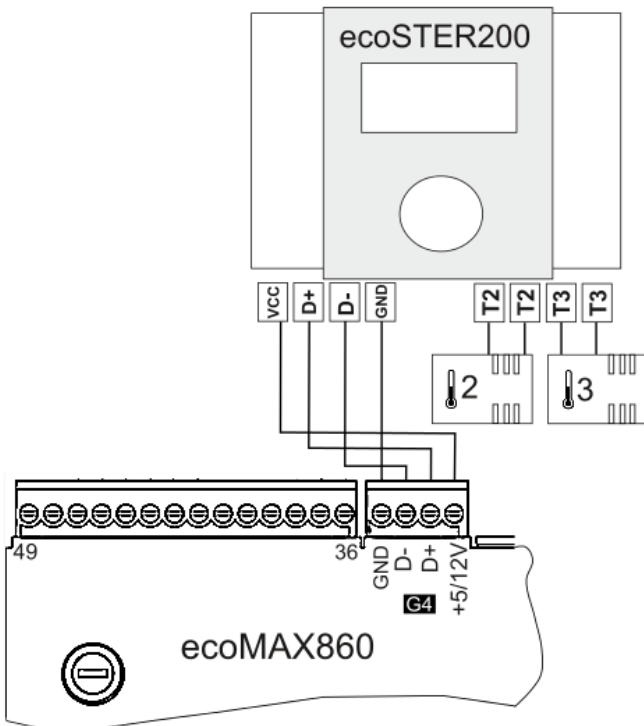

8.7 Assembling sensors of thermostat 2 and 3

After connecting two additional temperature sensors, the ecoSTER200 room panel provides independent temperature regulation in three rooms. Regulator cooperates with CT7 type room temperature sensors. Use a cable with a cross-section of at least 0.25 mm² to connect sensors. Recommended cross-section is 0.5 mm². Cable should not be longer than 20 m. Sensor cables should be separated from power cables (~230V). If not, incorrect temperature readings can occur. Minimum distance between sensor cables and power cables should be at least 10 cm.

In order to guarantee a maximum operation efficiency of the regulator, follow the recommendations concerning a place of sensor assembly:

1. Sensors should be assembled on a height app. 1.5 m over the floor level.
2. Avoid places which are strongly sunlit, close to heating devices, in direct vicinity of doors and windows, where a temperature measurement could be easily interfered by external conditions.
3. Avoid places with weak air circulation, e.g.: behind furniture.

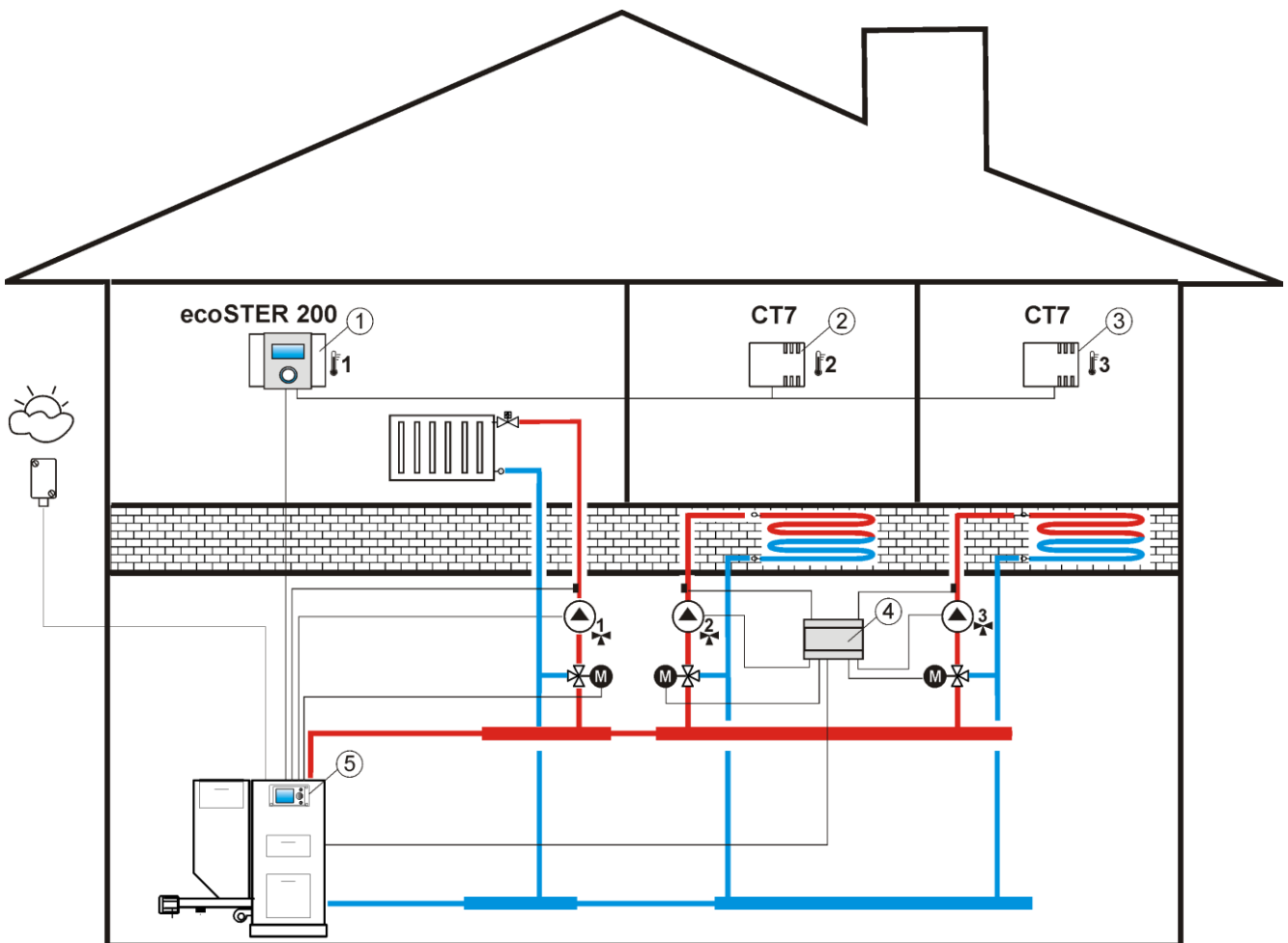

Fig. 8.1¹ Diagram of cooperation between ecoSTER200 and ecoMAX, where: 1 - ecoSTER200, 2 - room sensor of thermostat 2 type CT7, 3 - room sensor of thermostat 3 type CT7, 4 - module B (extends the system by 2 heat circulations), 5 - ecoMAX controller

¹ Diagram does not replace a project of installation and can be used only for reference.



**ul. Wspólna 19, Ignatki
16-001 Kleosin, Poland
phone +48 85 749-70-00
fax +48 85 749-70-14**

**plum@plum.pl
www.plum.pl
www.plumelectronics.eu**